



Westin

B U I L T - I N E X T R A C T I O N



Our high quality, built-in extraction systems allow you to design the perfect kitchen without compromise

The modern kitchen is as much a social space as it is a functional area for food preparation – which means that good kitchen extraction is less of a luxury than it is a necessity. However, the demand for effective kitchen extraction has increased due to the use of more powerful hobs and ranges.

The extensive range of Westin built-in extractors can satisfy this demand, making it possible to integrate a powerful extraction system into a kitchen without compromising the overall aesthetic.

Westin built-in units are also ideal for those kitchens where a hood is either inappropriate or impractical. Where cookers or ranges are sited in chimney alcoves or recesses, built-in extraction might be the only viable option.

The Westin built-in range includes the new ceiling extractor units which can be subtly integrated into the kitchen ceiling.

In addition, the downdraft units offer a unique and contemporary solution where an over-the-hob extractor is not desirable.



The Westin range of built-in units – effective but discreet kitchen extraction

Westin's comprehensive range of standard built-in units enable you to specify the right product for your application. The SM, SL and SLT models are general purpose units suitable for use with conventional 500 - 700mm wide hobs.

The SPC and SL901 units are designed for high-performance applications with widths up to 1,100mm, such as range cookers.



SLT & SPCT Models available with remote control

Built-in units for chimneys, recesses or in the furniture above the hob

SL900

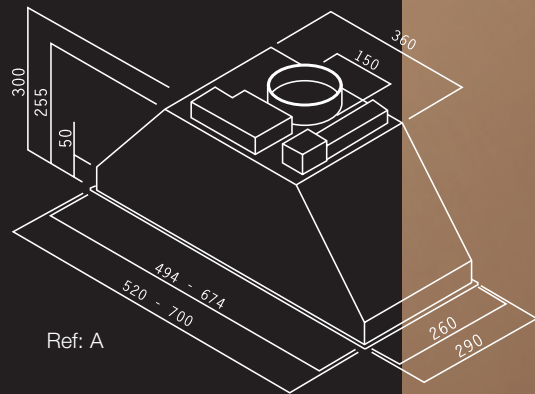
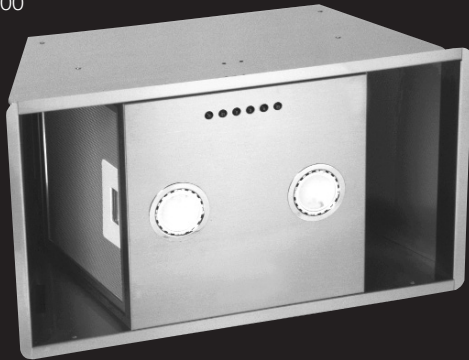

Ref: A

SPC900

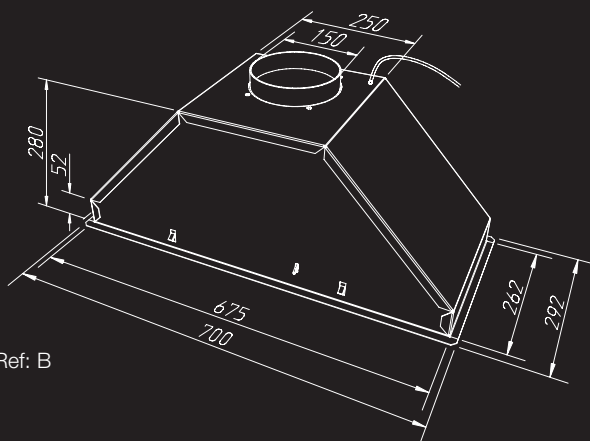
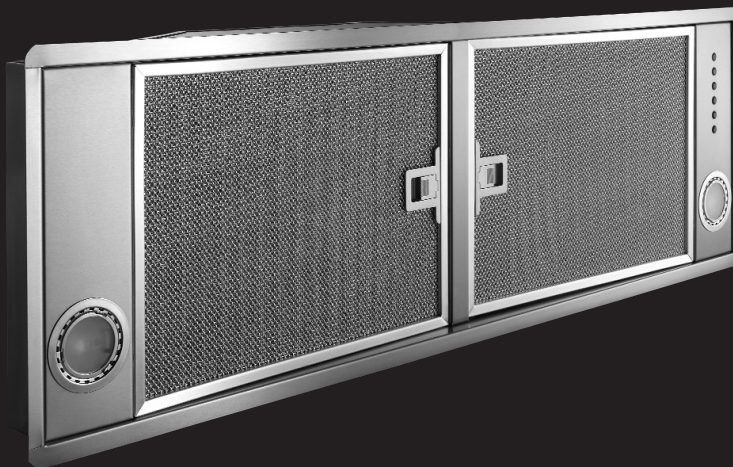

Ref: B

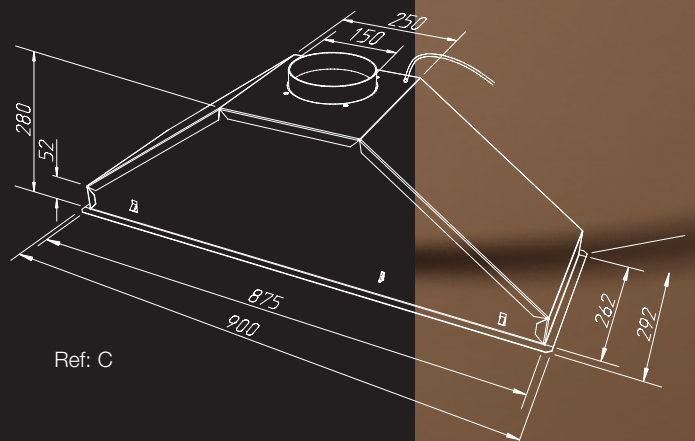

Ref: C

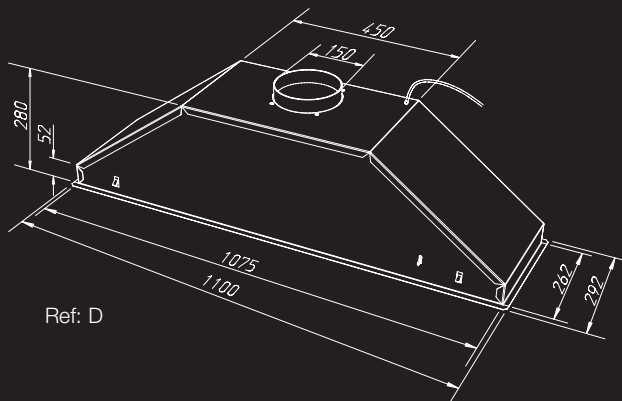

Ref: D

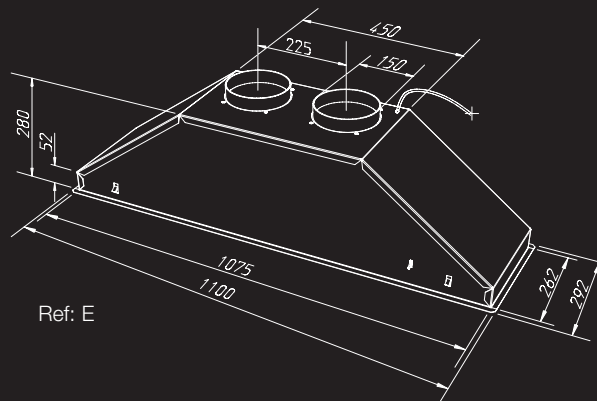

Ref: E

SL901

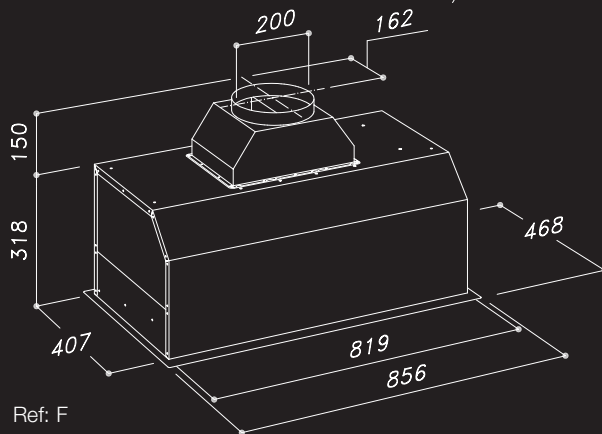

Ref: F

For further details please refer to table inside back cover

Downdraft extractors

- Discreet hideaway extraction
- Adjustable extraction height from 180 to 320mm
- Integrated and remote fan options
- Duct adaptors supplied to suit all available exhaust positions



SDD2

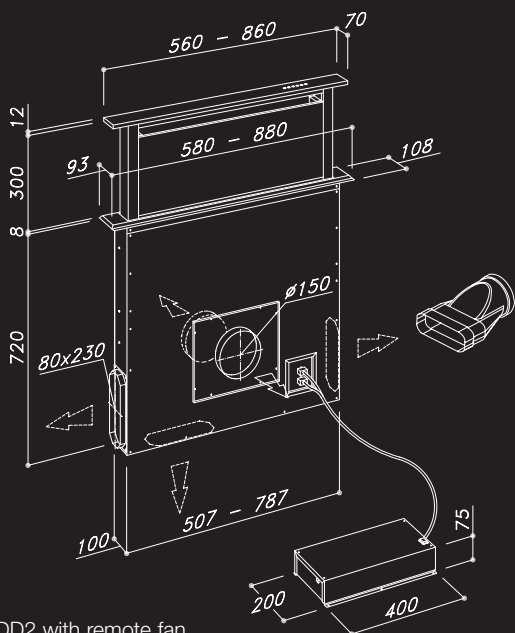

SDD2 with remote fan

Ref: G

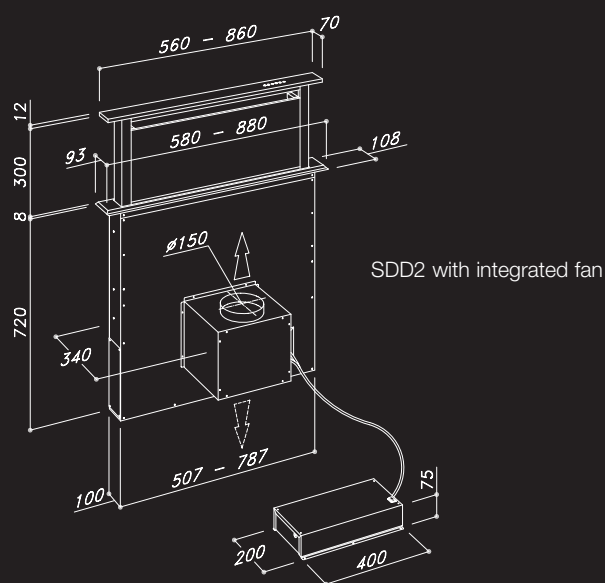

SDD2 with integrated fan

Ceiling built-in units

- Designed to fit between ceiling joists
- Comprehensive range of sizes
- Discreet modern design with uninterrupted line of sight across kitchen
- Internal and remote fan options
- Coloured versions available (stove enamel – CBU1 only)
- Single adjustable termination point for duct and electrics
- Radio remote control



CBU1 120 x 44



SLT950 / SLT951

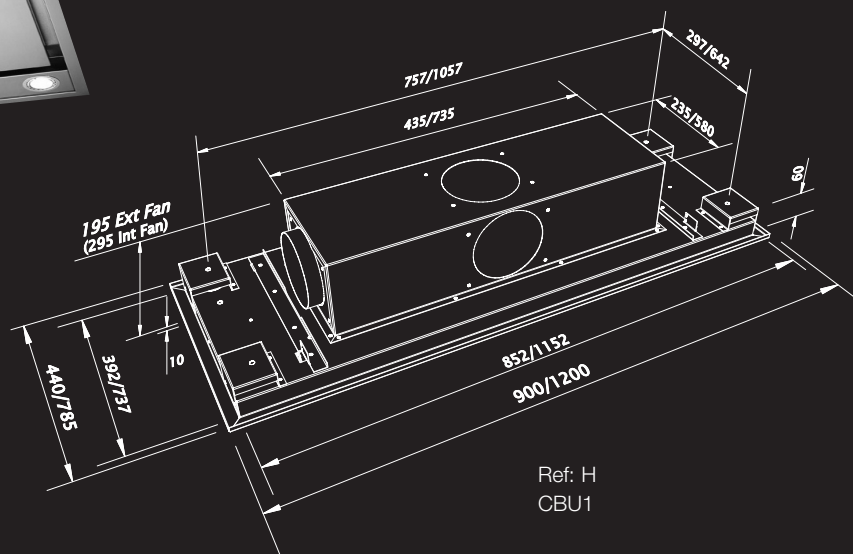

Ref: H
CBU1

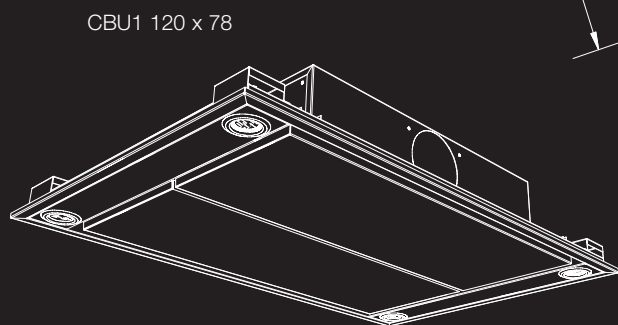

CBU1 120 x 78

Ref: J

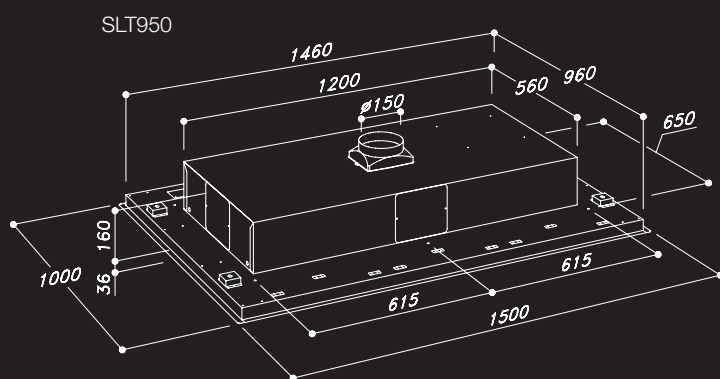

SLT950

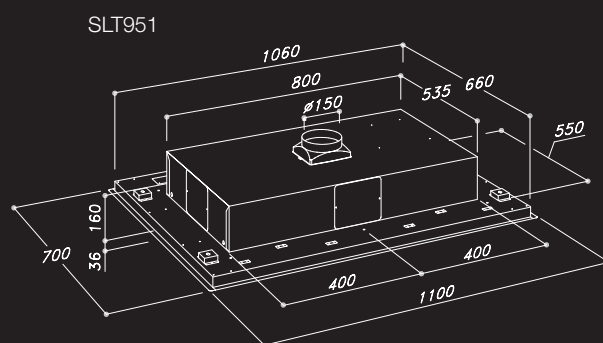

SLT951

Remote Fan Motors

In addition to an internal fan configuration, Westin offer three further options. The fan can be mounted in-line, within the duct route, or on an external wall or on the roof at the end of the duct route.

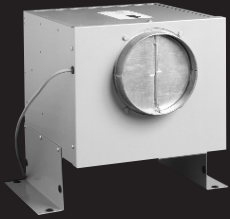

In-line Duct (SEM 1)
1,000m³/hr

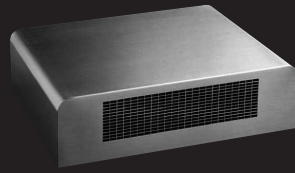

External Wall (SEM 2)
1,000m³/hr

1800m³/hr with
200mm duct spigot

1400m³/hr
with reducer for
150mm duct

External Wall (SEM 6)



External Roof (SEM 5)
1,000m³/hr

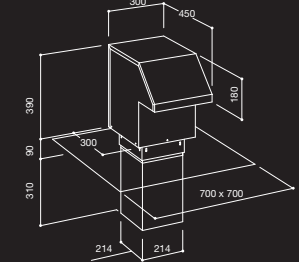
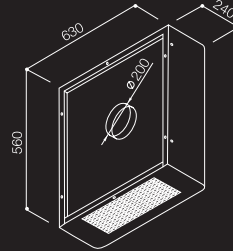
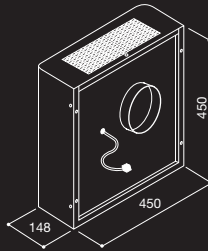
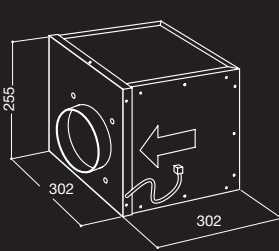

RESEARCH AND DEVELOPMENT – GLOBAL AND LOCAL EXTRACTION

In order to optimise kitchen extraction performance it is necessary to understand the processes involved and then to apply the correct type of extraction. Westin’s advanced R & D programme using Computational Fluid Dynamics (CFD) techniques has identified that the kitchen can be split into two extraction zones depending on their flow characteristics which are summarised in the following table:

CHARACTERISTICS OF EXTRACTION ZONES	
GLOBAL	LOCAL
Encompasses the whole room and contents e.g furniture, people	Bounded by volume between hob and extractor
Flow is slow: minutes or tens of minutes	Effects measured in seconds
Flow is complex with circulatory paths, eddies can “trap” contaminants	Flow dominated by plume creation & development
Global extraction removes fumes that have mixed with the air in the room	Efficient local extraction aims to remove fumes as they are produced

The effectiveness of extraction in each zone depends on the type of extractor used. The following table gives an approximate guide but you should consult with Westin on your final choice of extractor.

EFFECTIVENESS OF EXTRACTOR TYPE		
(FOR GUIDANCE ONLY – PLEASE CONSULT WESTIN ON YOUR CHOICE OF EXTRACTOR)		
Extractor Type	Global	Local
Hood	★★	★★★
Built-in unit over hob	★★	★★★
Ceiling built-in unit	★★★	★
Downdraft	★	★

Power, performance and planning

The efficiency of an extraction system is not just determined by fan motor power but also by the extractors' position, ducting and fan configuration.

The position of the hob and extractor unit is of great importance. It must allow for practical use and aesthetic values while at the same time provide a duct route which will optimise the performance of the extraction system. To some degree this could determine the layout of the kitchen.

In order to advise on these vital aspects, Westin prefer to assess an application at the early stages of planning, keeping in mind the type and specification of the cooker/hob, with some idea of the kind of cooking intended (ie griddling, frying, wok cooking, etc).

Important aspects of good ducting

Planning the route

An important influence on the performance of an extraction system is the ducting, which takes exhaust air from the extractor to the outside.

With many types of ducting and ducting accessories available, the ducting system and its route should be a prime consideration during the initial stages of a kitchen design.

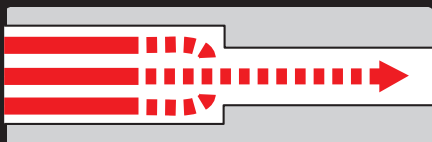

A reduction in the cross-sectional area can cause turbulence and increased resistance.

Efficiency

For maximum efficiency, ducting should be kept as short and as

straight as possible with a constant cross-sectional area being no less than that recommended by Westin.

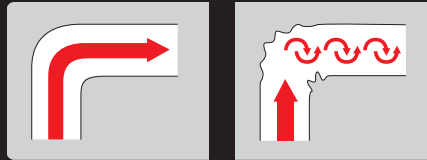

Bends should be kept as smooth as possible.

Bends in the duct will also degrade performance so the number of bends in a duct run should be kept to a minimum and be gradual and smooth to prevent turbulence.

Where possible, extraction units should be located on an outside wall or as near to an external vent as possible.

Ducting materials

Rigid ducting is the best type to use. It is designed for non-turbulent flow and will withstand the rigours of installation. It is easy to install providing there is suitable access to the route. Available in rectangular or circular sections, it comes in easy-to-use modular components such as bends, joints and adaptors.

If standard rigid components are unsuitable for the application, Westin can provide custom-designed metal ducting.

Flexible circular stainless steel flue liner is recommended for runs up disused chimneys. It is strong and designed to be pulled up tortuous flues without damage.

For inaccessible routes it may be necessary to use flexible aluminium foil ducting. Care should be taken to ensure that bends are gradual, that straight runs are pulled tight and that there are no kinks or deformations which reduce the cross-sectional

area and therefore degrade air flow. The aluminium foil is fragile and prone to puncture if care is not taken during installation.

Access

Easy access to the ducting route during installation is important. Lack of access may require the 'blind' fitting of flexible ducting, with increased risk of unseen kinks and impaired efficiency.

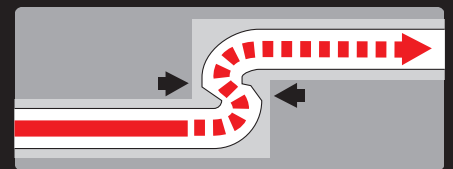

'Blind' fitting of flexible ducting, provides a greater risk of unseen kinks and impaired air flow.

Ventilation

As with all powerful extraction systems, adequate ventilation must be available to allow the replacement of fresh air equivalent to that vented by the extractor. It is important that ducting outlets are positioned away from fresh air sources to avoid exhaust fumes being recycled.



BUILT-IN EXTRACTORS					DUCT SPIGOT POSITION				FAN CONFIGURATION			OPERATOR CONTROLS			
Model	Width (mm)	Drawing Ref	Airflow m ³ /hr*	Duct Spigot Diameter (mm)	Top Exit	Rear Exit	Left Exit	Right Exit	Internal Fan	In-line Duct SEM1	External Wall SEM2/6†	Roof SEM5	Pushbutton Mech.	Pushbutton Electronic	Radio Remote
					Std	Special: Specify with order			Std	Supplied separately: Specify			3 speed	4 speed	4 speed
SM 900 - 52	520	A	650	150	•				•				•		
SM 900 - 70	700	A	650	150	•				•				•		
SL 900 - 52	520	A	800	150	•				•					•	
SL 900 - 70	700	A	800	150	•				•					•	
SLT 900 - 52	520	A	800	150	•				•						•
SLT 900 - 70	700	A	800	150	•				•						•
SL 900 - 52 EM	520	A	1000	150	•					•	•	•		•	
SL 900 - 70 EM	700	A	1000	150	•					•	•	•		•	
SLT 900 - 52 EM	520	A	1000	150	•					•	•	•			•
SLT 900 - 70 EM	700	A	1000	150	•					•	•	•			•
SL 901	856	F	1600	200	•				•						
SPC 700	700	B	1000	150	•	•	•	•	•					•	
SPC 900	900	C	1000	150	•	•	•	•	•					•	
SPC 1100	1100	D	1000	150	•	•	•	•	•					•	
SPC 1100/2	1100	E	2000	2x150	•				•					•	
SPCT 700	700	B	1000	150	•	•	•	•	•						•
SPCT 900	900	C	1000	150	•	•	•	•	•						•
SPCT 1100	1100	D	1000	150	•	•	•	•	•						•
SPC 700 EM	700	B	1000	150	•	•	•	•		•	•	•		•	
SPC 900 EM	900	C	1000	150	•	•	•	•		•	•	•		•	
SPC 1100 EM	1100	D	1000	150	•	•	•	•		•	•	•		•	
SPCT 700 EM	700	B	1000	150	•	•	•	•		•	•	•			•
SPCT 900 EM	900	C	1000	150	•	•	•	•		•	•	•			•
SPCT 1100 EM	1100	D	1000	150	•	•	•	•		•	•	•			•

DOWNDRAFT EXTRACTORS			SPECIFICATION		DUCT SPIGOT DIRECTION			FAN CONFIGURATION			TOP PANEL & CONTROLS	
Model	Drawing Ref	Width	Airflow m ³ /hr*	Duct Spigot Diameter	Down	Front/Back	Left/Right	Integrated Fan	In-line Duct	External Wall	Stainless Steel Pushbutton	Black Glass Touch Controls
					Adjustable			SDD-2	SEM1	SEM2/6†	4 speed	4 speed
SDD2 CM 58 X	G	580	1000	150	•	•	•	•	•	•	•	
SDD2 CM 86 X	G	880	1000	150	•	•	•	•	•	•	•	
SDD2 TC CM 58 GLASS	G	580	1000	150	•	•	•	•	•	•		•
SDD2 TC CM 86 GLASS	G	880	1000	150	•	•	•	•	•	•		•

CEILING BUILT-IN EXTRACTORS					FAN CONFIGURATION				SPECIFICATION			DUCT SPIGOT POSITION			CONTROL	
Model	Drawing Ref (mm)	Width (mm)	Depth (mm)	Height required (mm)	Ceiling cutout (W x D)	Internal	In-line Duct SEM1	External Wall SEM2/6†	Roof SEM5	Airflow m ³ /hr*	Duct Spigot Diameter (mm)	Lighting	Top	Front/Back	Left/Right	Radio Remote 4 speed
						Supplied separately: Specify										
CBU1 90x44 EM	H	900	x 440	x 200	855 x 395		•	•	•	1000	150	4 x 20W	•	•	•	•
CBU1 120x44 EM	H	1200	x 440	x 200	1155 x 395		•	•	•	1000	150	4 x 20W	•	•	•	•
CBU1 90x44 INT	H	900	x 440	300	855 x 395	•				1000	150	4 x 20W	•	•	•	•
CBU1 120x44 INT	H	1200	x 440	x 300	1155 x 395	•				1000	150	4 x 20W	•	•	•	•
CBU1 90x78 EM	H	900	x 785	x 200	855 x 740		•	•	•	1000	150	4 x 20W	•	•	•	•
CBU1 120x78 EM	H	1200	x 785	x 200	1155 x 740		•	•	•	1000	150	4 x 20W	•	•	•	•
CBU1 90x78 INT	H	900	x 785	x 300	855 x 740	•				1000	150	4 x 20W	•	•	•	•
CBU1 120x78 INT	H	1200	x 785	x 300	1155 x 740	•				1000	150	4 x 20W	•	•	•	•
SLT 950	J	1500	x 1000	x 200	1465 x 965		•	•	•	1000	150	4 x 20W	•	•	•	•
SLT 951	J	1100	x 700	x 200	1065 x 665		•	•	•	1000	150	4 x 20W	•	•	•	•

*Maximum volume when tested in free air
†External Wall: SEM 6, 1800m³/hr with 200mm duct spigot, 1400m³/hr with reducer for 150mm duct

Westin offer a comprehensive range of
products and services, including:

Custom-designed extraction systems

Built-in extraction

Decorative metalwork including worktops, doors and splashbacks

Westin Hood Selection

After sales service

Site surveys

Technical and sales training



W S Westin Ltd
Phoenix Mills, Leeds Road
Huddersfield HD1 6NG
www.westin.co.uk

For further information, general enquiries or quotations please contact Westin on:

Tel: 01484 421585 • Fax: 01484 432420
Email: sales@westin.co.uk